



Technical specification

# Recycler WR 2400



# Technical specification

		<b>Recycler WR 2400</b>	
<b>Working width (max.)</b>		2,400 mm	
<b>Working depth <sup>*1</sup></b>		0 – 500 mm	
<b>Milling and mixing rotor</b>			
Tool spacing		20 mm	
Number of tools		186	
Drum diameter with tools		1,480 mm	
<b>Engine</b>			
Manufacturer		Mercedes-Benz	
Type		OM 502 LA AG3	
Cooling		Water	
Number of cylinders		8	
Output		420 kW/563 HP/571 PS	
Engine speed		2,000 min <sup>-1</sup>	
Displacement		15,900 cm <sup>3</sup>	
Fuel consumption		100 l/h	
Fuel consumption, <sup>2/3</sup> load		67 l/h	
<b>Speeds/Gradeability</b>			
1 <sup>st</sup> advance speed		0 – 20 m/min	
2 <sup>nd</sup> advance speed		0 – 40 m/min	
3 <sup>rd</sup> advance speed		0 – 90 m/min	
4 <sup>th</sup> advance speed		0 – 200 m/min	
Theoretical gradeability, max.		57 %	
Transversal inclination, max		8°	
Ground clearance		approx. 400 mm	
<b>Weights</b>			
Front axle load, full tanks, max.		16,000 daN (kg)	
Rear axle load, full tanks, max.		13,000 daN (kg)	
Own weight <sup>*2</sup>		25,700 daN (kg)	
Operating weight, CE <sup>*3 *2</sup>		26,500 daN (kg)	
Operating weight, full tanks		29,000 daN (kg)	
<b>Tyres</b>			
Type of tyres		Radial	
Tyre size, front / rear		28 L 26	
<b>Tank capacities</b>			
Fuel tank		1,200 l	
Hydraulic fluid tank		350 l	
Water tank		500 l	
<b>Electrical system</b>		24 V	
<b>Shipping dimensions</b>			
Truck transport dimensions (L x W x H)		9,050 x 3,000 x 3,000 mm	
Ocean transport dimensions (L x W x H)		9,200 x 3,200 x 3,200 mm	

<sup>\*1</sup> = The maximum working depth may deviate from the value indicated, due to tolerances and wear.

<sup>\*2</sup> = The weights refer to basic machine including operator's cabin with air conditioning, but without any other additional equipment.

<sup>\*3</sup> = Weight of machine with half-full water tank, half-full fuel tank, driver (75 kg) and tools.

Dimensions in mm

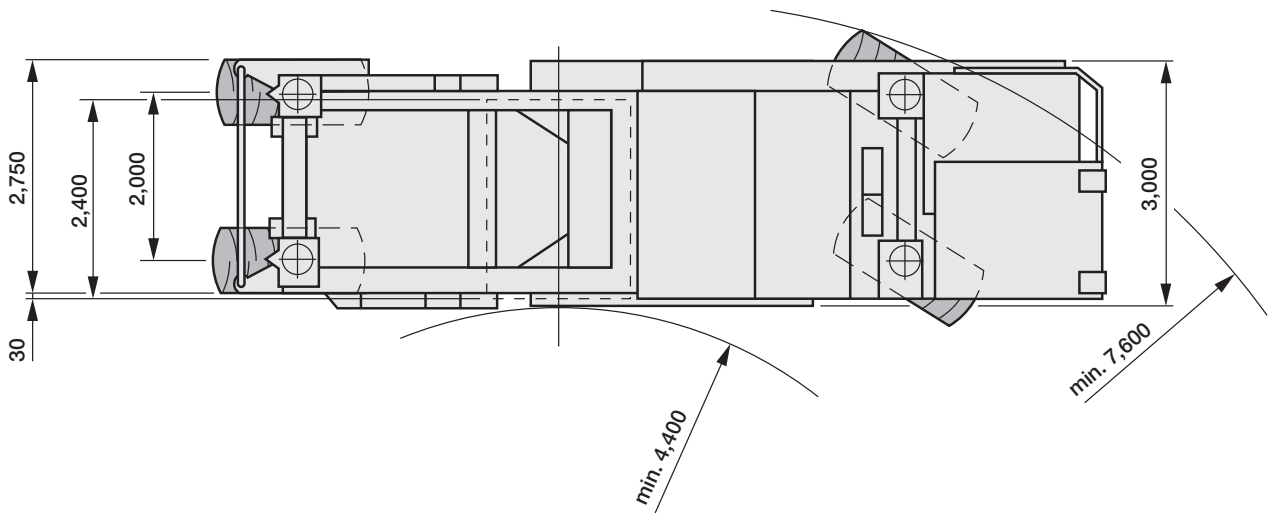
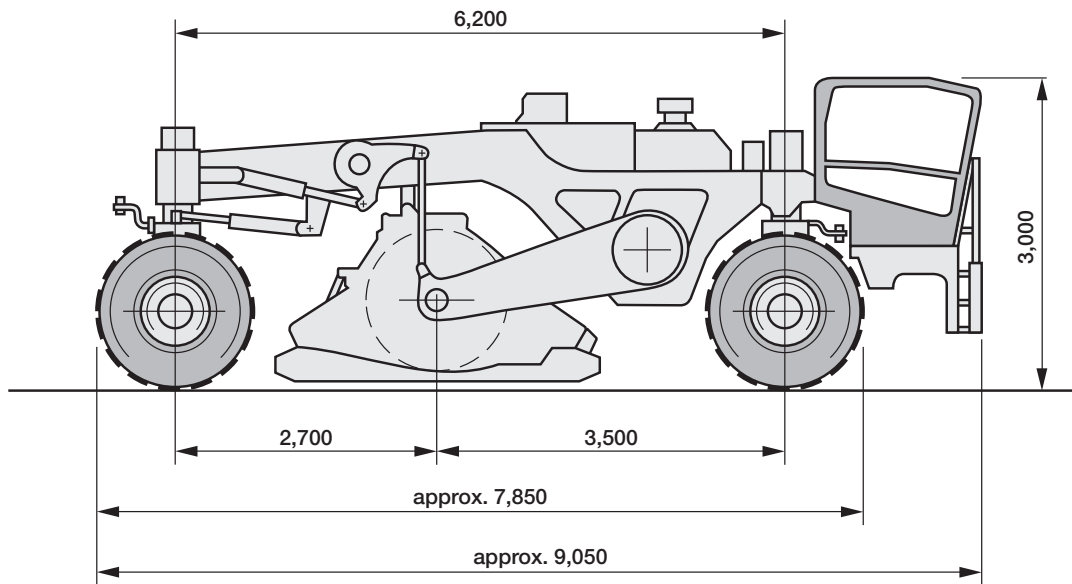

## Basic design

Cold recycler with mechanically driven milling and mixing rotor and two working directions.

## Chassis

Rigid welded construction with mounts for the individual units and attachments.

The water tank is integrated into the chassis.

All components are easily accessible for maintenance and servicing.

## Soundproofing

Noise levels are reduced by the standard soundproofing which also protects both the operating personnel and the environment against any nuisance due to noise.

## Operator's platform

The operator's platform with seat and control console is located at the front of the machine.

The steering wheel can be tilted and adjusted in height.

The ergonomic sitting position, low machine design and clear overview allow an easy operation of the machine.

The modern control and operating elements are located within easy reach and within the operator's field of vision.

The entire platform can be shifted to either side beyond the outer edge of the machine.

In addition, the seat console (driver's seat and control consoles) can be infinitely turned by 90° to ensure an optimum overview of the working environment at all times.

## Operator's cabin

The recycler is equipped with a fully enclosed, elastically mounted operator's cabin. It provides optimum protection against inclement weather and can, upon request, be supplied with an air-conditioning system.

Heated front and rear screens are a standard feature.

The cabin is equipped with an additional seat.

The entire cabin can be shifted to the right beyond the edge of the machine.

## Machine control CGC (Cockpit Graphic Centre)

All machine functions are controlled or regulated by means of microcontrollers. All control modules are accommodated in an easily accessible control cabinet.

The operator has immediate access to data, such as operating hours, oil pressure, engine temperature, engine speed, hydraulic fluid temperature, filling level of the diesel tank, wheel position, milling depth, travel speed, job data, etc., via the CGC display at the operator's platform.

If necessary, the integrated Wirtgen information and diagnosis system generates visual and audible alarms.

The data and messages, e.g. contamination of hydraulic fluid filter or air filter, are indicated on the display of the CGC at the operator's platform.

All inputs for the calibration of the recycler are made via the CGC. The job data can be indicated on the display or printed via an optional printer.

## Power unit

The machine is driven by a modern, powerful 8-cylinder engine. The engine complies with the stringent requirements of the exhaust emission standards stipulated by the US Environmental Protection Agency (EPA, Tier III) and the EU (Stage III a).

It is equipped with a fully electronic engine management system and offers maximum torque stability even at extreme engine loads, thus preventing breaks in operation.

The engine is mounted elastically, thus minimizing the propagation of sound and vibration.

An extremely large cooler surface effectively cools the engine and other components, thus allowing the safe operation of the machine even at high outside temperatures.

The cooling system is additionally equipped with a fan controller. The fan speed is reduced at low ambient temperatures or low loads, thus reducing the noise emission levels and fuel consumption.

All servicing work on the engine can be carried out from the ground.

## Power control

The machine is equipped with an automatic power control which governs the advance speed in accordance with the engine load. The power control can be deactivated to allow manual adjustment of the advance speed.

## Milling and mixing rotor drive

The milling and mixing rotor is driven mechanically by the diesel engine via a mechanical clutch and power belts

acting on the planetary gearbox. The power belts are tensioned automatically by means of hydraulic cylinders. Four possible speeds of the milling and mixing rotor ensure optimum working results.

#### **Milling and mixing rotor**

The milling and mixing rotor operates in up-milling or down-milling direction, depending upon the direction of travel. Quick-change toolholders type HT11, which accommodate the point-attack cutting tools, are welded onto the drum body.

Special, individually replaceable edge segments are additionally mounted onto the outer edges of the drum. Hydraulically adjustable scraper blades in front of and behind the drum ensure good mixing results.

The pre-set aperture angle of the crusher bar and/or the scraper blade respectively is indicated on the display.

#### **Cutting tool replacement**

The hydraulically swivelling scraper blade provides good access to the milling and mixing rotor for the replacement of tools. The quick-change toolholder system minimizes the time required for maintenance work.

Turning of the milling and mixing rotor for the replacement of tools is facilitated considerably by means of a hydraulically operated drum turning device (equipment option).

#### **Milling depth control**

The machine is set in transport or working position by means of the four lifting columns.

The working depth is adjusted by lowering the milling and mixing rotor.

The current working depth is indicated on the display at the operator's platform.

#### **Drive unit**

The wheels of the recycler WR 2400 are connected to the chassis by means of hydraulically height-adjustable cylindrical columns.

The machine's current height position can be read on the display and/or stored for subsequent operations.

A special feature ensures that all 4 wheel brackets are fully balanced in height, thus allowing convenient off-road driving and precise recycling and stabilizing work.

#### **Travel drive**

Each wheel is driven by its own hydraulic motor.

The hydraulic motors are fed by a hydraulic variable displacement pump.

The four travel speeds can be infinitely varied from zero to maximum working speed in milling and travel gear.

A switchable differential lock ensures uniform traction.

The advance speed is regulated at the operator's platform.

#### **Brake system**

Braking is achieved by the self-locking hydrostatic transmission. In addition, the wheels can be locked from the operator's platform by means of a multiple-disk parking brake.

#### **Steering**

The WR 2400 has a finger-light hydraulic four-wheel steering system. By means of a selector switch, the operator can choose between three different steering modes ("normal", "crab steering" and "coordinated steering").

The front wheels are steered via the steering wheel, while sensors automatically maintain the rear wheels in straight-ahead position. They can, however, also be operated independently of the front wheels via a joystick.

#### **Hydraulic system**

Independent hydraulic systems for travel drive, setting functions and cooling system.

The hydraulic pumps are driven by the diesel engine via a splitter gearbox.

#### **Electrical system**

24 V electrical system with starter, three-phase alternator and two 12 V batteries, as well as complete working lights, including two freely positionable lamps with magnetic pedestals.

#### **Cold recycling systems: Injection system for water or binding agents with one injection bar (800 l/min)**

The injection system consists of a microprocessor-controlled metering unit, an eccentric pump, an injection bar with 16 nozzles and a pushing device for tanker trucks. The pump delivers the liquid agent (e.g. water or bitumen emulsion) from a tanker truck to the injection bar.

The eccentric worm pump has a maximum delivery rate of 800 l/min.

A flow meter monitors the delivered quantities and transfers the data to the microprocessor control, which in turn regulates the addition of binding agent or water in accordance with the pre-selected parameters and/or the advance speed.

An automatic shut-off device enables the individual nozzles to be opened and closed by means of hydraulic cylinders, thus allowing the addition of binding agents to be effectively adapted to the working width.

The nozzles are cleaned automatically.

#### **Injection system for water and binding agents with 2 injection bars**

A second pump can be integrated to facilitate the simultaneous addition of water and bitumen emulsion into the mixing chamber via two separate injection bars.

The addition is also governed by means of a microprocessor-controlled metering unit.

#### **Injection system for foamed bitumen (500 kg/min)**

The injection system for foamed bitumen comprises a pump and an injection bar with 16 nozzles for foamed bitumen.

Foaming takes place in special expansion chambers in the injection bar. The hot bitumen is delivered by an electrically heated gear pump and is subsequently filtered.

A flow meter registers the delivered quantity of bitumen.

The addition of water and air, which are necessary for the foaming process, is governed in accordance with the bitumen quantity.

All hot-bitumen hoses in the machine are insulated and heated.

The temperature is continuously measured and maintained at the pre-set value by means of a control system.

The water for the foaming process is taken from the integrated water tank of the machine.

The system is equipped with a test nozzle to check the quality of the foam.

A second injection system is provided for the addition of water to achieve the optimum moisture content of the mixture.

It consists of an eccentric pump and an injection bar with 16 nozzles for water.

The water is delivered from a preceding water tanker.

#### **Injection system for water with one injection bar (1,800 l/min)**

The injection system consists of a microprocessor-controlled metering unit, a pump, a manual injection bar with 16 nozzles and a pushing device for tanker trucks.

The pump delivers water from a tanker truck to the injection bar.

The pump has a maximum delivery rate of 1,800 l/min.

A flow meter monitors the delivered quantities and passes the data to the control system, which regulates the addition of water in accordance with the pre-selected parameters.

The addition of binding agents can be adapted to the working width manually.

#### **Filling**

Water and diesel fuel are filled via large filling ports.

#### **Safety during transport**

The machine can be securely lashed onto a low-bed trailer or loaded by crane with the aid of lashing lugs.

Equipment	Recycler WR 2400
<b>Operator's platform</b>	
Driver's seat with control consoles, can be infinitely turned by 90°	○
Cabin, side-shifting	○
Air-conditioning system	●
Special painting	●
<b>Machine control and levelling system</b>	
Machine control by means of microcontrollers	○
CGC (Cockpit Graphic Centre)	○
Printer for job data	●
Slope control sensor for slope adjustment	●
<b>Milling drum assembly</b>	
Quick-change toolholder system HT11 with 22 mm shaft diameter	○
Quick-change toolholder system HT11 with 20 mm shaft diameter	●
Crusher bar	●
Pneumatic knock-out tool	●
Hydraulic drum turning device (for cutting tool replacement)	●
<b>Cold recycling system</b>	
Injection system with 1 pump and 1 automatic injection bar (800 l/min)	●
Injection system with 2 pumps and 2 automatic injection bars (800 l/min)	●
Injection system for foamed bitumen and water (i.e. 2 pumps and 2 injection bars)	●
Injection system with 1 pump and 1 manual injection bar (1,800 l/min)	●
Hose connections to bitumen tanker truck, various lengths, types	●
Additional water tank for foamed bitumen	●
Additional push rod	●
<b>Miscellaneous</b>	
Soundproofing	○
Cyclonic air filter	○
Working lights (detachable)	○
Warning lights	○
Horn, reversing horn and exterior rear view mirrors	○
Towing device	○
4-wheel steering	○
Loading and lashing lugs	○
Comprehensive tool kit	○
CE label	○
Safety certificate by the Employer's Liability Insurance Association	○
Comprehensive safety package with emergency stop buttons	○
Compressed air system	○
High-pressure water wash down	●
Operation of the cold recycler with organic hydraulic fluid	●

○ Standard ● Option



Wirtgen GmbH  
Reinhard-Wirtgen-Strasse 2 · 53578 Windhagen · Germany  
Phone: +49 (0) 26 45/131-0 · Fax: +49 (0) 26 45/131-242  
Internet: [www.wirtgen.com](http://www.wirtgen.com) · E-Mail: [info@wirtgen.com](mailto:info@wirtgen.com)